

3-way Control Valve type G3FMT-SL

Nodular cast iron, PN10, DN125 - DN 550 & DN 650 mm

0-2.6.16-G

Page 1 of 4

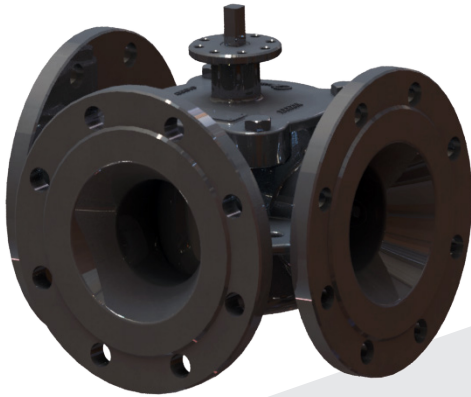

APPLICATIONS

Control valve type G3FMT-SL is a three-way control valve with a slide for quarter turn operation designed for regulating of fresh water, lubricating oil and other liquid media. The valves are designed for use in conjunction with industrial processes, district heating and marine installations with large water or lubricating oil volumes:

- Engine Jacket Cooling Water System
- Lubricating Oil Cooling
- Central Cooling Water System, etc.

The valves are designed for use in conjunction with valve motor type CAR-H with handle for manual operation or for use in conjunction with a pneumatic actuator type VT.

DESIGN

The valve body and the valve slide are made of nodular cast iron. The valve flanges are drilled according to EN 1092-2 - option JIS B 2210 5K/10k and ANSI class 150.

FUNCTION

The slide is firmly connected with the motor spindle. When the slide is in the one outer position by turning the spindle, connection A-AB is fully open and connection B-AB is fully closed. In the other outer position connection A-AB is fully closed and connection B-AB is fully open. In the intermediate positions the opening degrees change proportionally. The valve has a small tolerance between body and slide.

Connection described for AB-Left valves - reverse connection for AB-Right valves.

This section to be read together with sketches page 2 this data sheet.

TECHNICAL DATA

Materials:

- Valve body, slide	Nodular cast iron EN-GJS-400-15
- Sealing element and O-ring	Silicone/PTFE

Flow characteristic Almost linear

Leakage rate ANSI class I

Flanges EN 1092-2 PN 10
- Option JIS B 2210 5K/10K
ANSI class 150

Max. pressure Δp , against which the valve can close 5 bar

Nominal pressure PN 10

Design temperature 120°C

FEATURES

- Simple design secures reliable controls and reduces costly downtime
- Most compact valve on the market
- Full flexibility on port orientation AB right or AB left

Subject to change without notice.

www.cloriuscontrols.com

PORT NUMBERING: AB-RIGHT



PORT NUMBERING: AB-LEFT

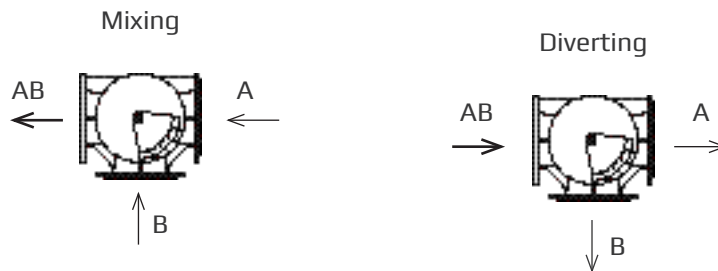

MOUNTING

The valve connections are marked A, B and AB. The slide is operating between A and B. Check slide position before installation in the pipe. The slide position is marked on the top of the shaft. The valves can be installed with vertical as well as horizontal spindles. The valves must be mounted in a way that the valve actuator will be exposed to a minimum of moisture and unnecessary vibrations.

3-way Control Valve type G3FMT-SL

Nodular cast iron, PN10, DN125 - DN 550 & DN 650 mm

0-2.6.16-G

Page 3 of 4

DIMENSION SKETCH

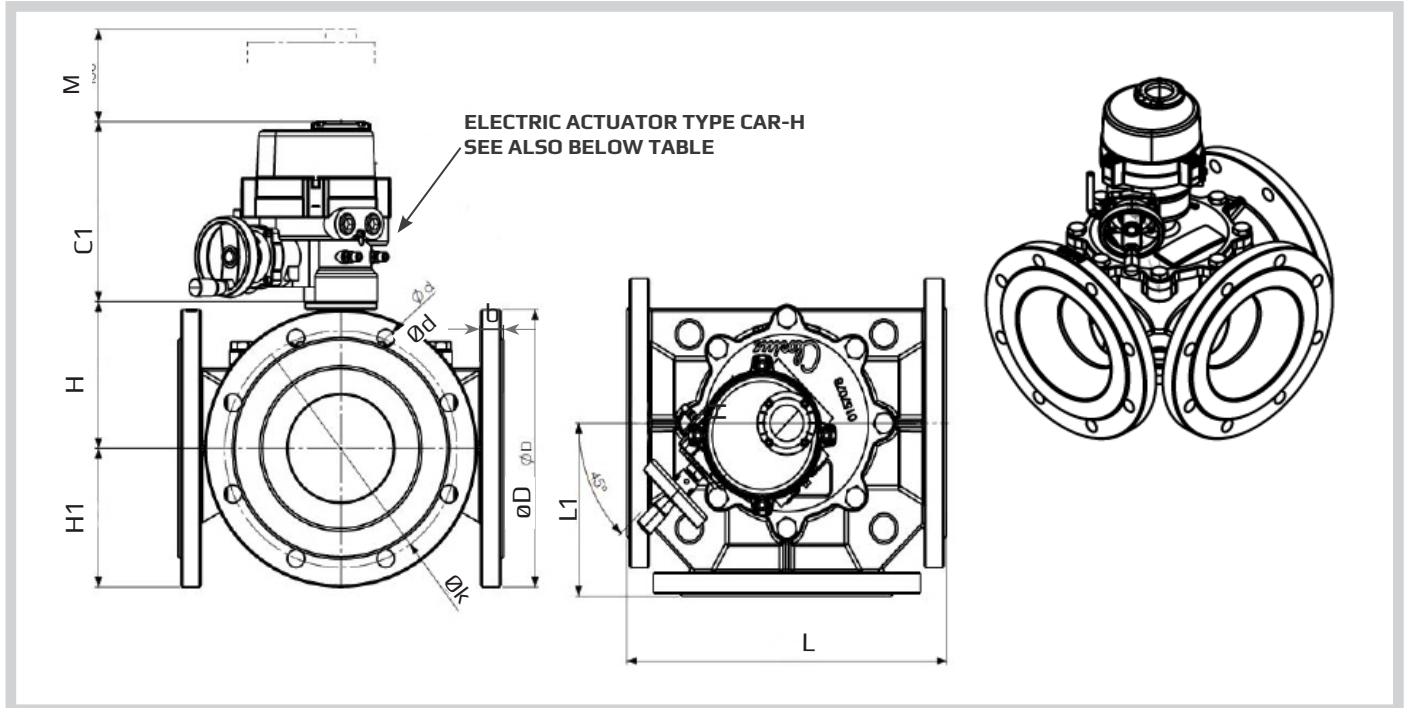

SPECIFICATIONS - TABLE 1 (read this together with table on page 4)

Type	L (mm)	L1 (mm)	H (mm)	H1 (mm)	b (mm)	C1 (mm)	M (mm)	Electric Actuator Type CAR-H
125 G3FMT-SL	330	165	140	ØD/2	24	223	110	CAR-H 006
125 G3FMT-SL JI55K	320	160	140	ØD/2	19	223	110	CAR-H 006
150 G3FMT-SL	356	178	149	ØD/2	25,4	223	110	CAR-H 006
200 G3FMT-SL	410	205	182	ØD/2	28,4	223	110	CAR-H 010
200 G3FMT-SL (*L)	484	242	182	ØD/2	28,4	223	110	CAR-H - 010
250 G3FMT-SL	480	240	202	ØD/2	31	223	110	CAR-H -010
300 G3FMT-SL (**RF)	580	290	202	ØD/2	32	223	110	CAR-H 010
300 G3FMT-SL	560	280	237	ØD/2	32	261	150	CAR-H -020
350 G3FMT-SL	660	330	256	ØD/2	36	261	150	CAR-H 024
400 G3FMT-SL	720	360	278	ØD/2	38	315	180	CAR-H 035
500 G3FMT-SL	840	420	308	ØD/2	32	315	180	CAR-H 050
550 G3FMT-SL	840	420	308	ØD/2 ¹	32	315	180	CAR-H 050
650- G3FMT-SL	950	475	339	ØD/2	32	353	200	CAR-H 080

* Long Version
** Reduced Flow

ØD/2 - Depends on flange type (see also table 2)

Subject to change without notice.

**SPECIFICATIONS -
TABLE 2**

Flange connections	EN 1092-2			ANSI Class 150			JIS B 2210 5K			JIS B 2210 10K		
	D (dia.) (mm)	k (dia.) (mm)	d mm dia. (number)	D (dia.) (mm)	k (dia.) (mm)	d mm dia. (number)	D (dia.) (mm)	k (dia.) (mm)	d mm dia. (number)	D (dia.) (mm)	k (dia.) (mm)	d mm dia. (number)
DN125	250	210	19x(8)	255	216	22x(8)	235	200	19x(8)	250	210	23x(8)
DN150	285	240	23x(8)	280	241	22x(8)	265	230	19x(8)	280	240	23x(8)
DN200	343	295	22x(8)	343	298	22x(8)	320	280	23x(8)	330	290	23x(12)
DN250	405	350	23x(12)	405	362	25x(12)	385	345	23x(12)	400	355	25x(12)
DN300	455	400	23x(12)	483	432	25x(12)	430	390	23x(12)	445	400	25x(16)
DN350	505	460	23x(16)	533	476	29x(12)	480	435	25x(12)	490	445	25x(16)
DN400	565	515	28x(16)	597	540	29x(16)	540	495	25x(16)	560	510	27x(16)
DN500	670	620	28x(20)	699	635	32x(20)	655	605	25x(20)	675	620	27x(20)
DN550	-	-	-	-	-	-	720	665	27x(20)	745	680	33x(20)
DN650	-	-	-	-	-	-	825	770	27x(24)	845	780	33x(24)

SPECIFICATIONS - TABLE 3

Type	Flange connection	KvS m ³ /h	Torque Nm	Weight kg
DN125	125	260	40	34
DN150	150	430	45	42
DN200	200	770	90	67
DN250	250	1.230	115	96
DN300 (**RF)	300	1.190	115	142
DN300	300	2.030	160	130
DN350	350	2.850	210	175
DN400	400	3.760	265	220
DN500	500	4.560	396	249
DN550	550	4.560	396	298
DN650	650	5.890	640	483

KvS-value for port A and B 50% open

*Torque calculated at max ΔP for: DN100 - 300 - 5 Bar

**NOTE: KvS is max. KvS value